



**Rhino Baritric
Patient Lifter P655
Operating Manual**

ATTENTION

Before using this Medical Device read this manual. If you are unable to understand, contact your equipment provider for technical support before attempting to use this product.

TABLE OF CONTENTS

Table of Contents	1
Specifications	2
Product Diagram	3 - 4
General Guidelines	5 - 7
Assembly	
Assembling the Mast Assembly to the Base	8 - 10
Attaching the Control Unit on Mounting Bracket	11 - 12
Attaching the Battery Pack on Control Unit	13 - 14
Installing the Optional Scale	15 - 16
Charging The Battery	18 - 19
Operation	20 - 22
Lifting the Patient	23 - 25
Transferring the Patient	26
Transferring Patient from and to bed	27 - 30
Transferring Patient from and to wheelchair	31
Transferring Patient from and to floor	32
Transferring Patient from and to Automobile	33 - 34
Lift Sling Type Reference	35 - 36
Maintenance	37
Trouble Shooting	38 - 39
Limited Warranty	40

SPECIFICATIONS

Height at Sling Hook-up - MAX.: 75 inches
Height at Sling Hook-up - MIN.: 30 inches
Base Width OPEN: 41 inches
Base Width CLOSED: 22 inches
Base Height (Clearance): 4.5 inches
Base Length: 47.5 inches
Overall Height: 53.5 inches
Overall Length: 50 inches
Overall Width: 26 inches
Casters: 3" Dual Front and 5" Rear with Brake
Sling Options: Transfer
Sling Material: Nylon/Polyester
Weight Capacity: P655 - 600 lbs
Weight without sling: P655 - 130 lbs
Battery: 24V DC, 5 Amps
Charger Input: 100-240V AC
Charger Output/Charging Time: 29.5V DC Max 6 hours
Motor Safety Devices: Anti-Entrapment
Emergency Stop Button: Yes
Limited Warranty Lifter/Electronics: 3 Years/1 Years

PRODUCT DIAGRAM

ELECTRIC PATIENT LIFTER P655

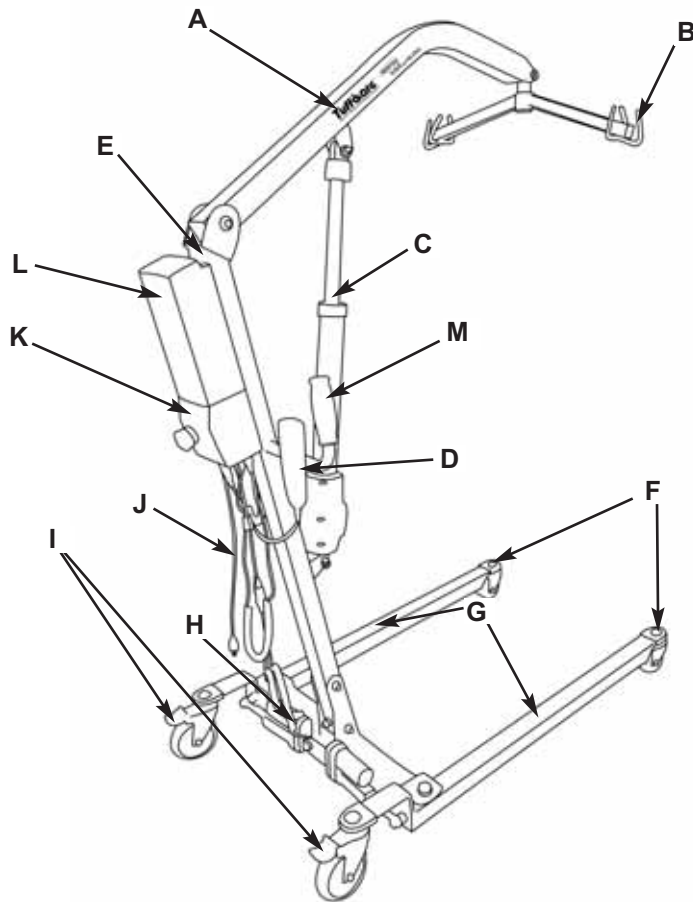

- | | |
|---------------------------------|------------------------------|
| A. Lift Arm | B. Attachment (Sling) Cradle |
| C. Up-Down Actuator | D. Hand Pendant |
| E. Mast | F. Dual Front Caster Wheels |
| G. Adjustable Base | H. Dual Base Actuator |
| I. Rear Caster Wheel with Brake | |
| J. Charging Cord | K. Control Unit |
| L. Battery Pack | M. Push Handle Bar |

DANGER! RISK OF ELECTRICAL AND FIRE HAZARD. MAY RESULT IN DEATH, SERIOUS INJURY, SHOCK OR BURNS.

This charger, like all electrical products. MUST be treated with respect. Follow these instructions to reduce electrical hazard risk.

TO HELP REDUCE THIS RISK: PROPER GROUNDING OF AC POWER CORD

Charger MUST be grounded to reduce risk of electric shock. Charger is equipped with an electric cord that has an equipment grounding conductor and a grounding plug. The plug MUST be plugged into an outlet that is properly installed and grounded in accordance with all local codes and ordinances. If you ever feel even a slight shock from this or any electrical appliance, or equipment connected to it, such as your chair or carrier STOP. Turn off electricity to the outlet, and have it inspected by an electrician. You may have a dangerous, improperly wired outlet.

DANGER - NEVER alter AC power cord or plug provided. If it will not fit outlet, have a proper outlet installed by a qualified electrician. Improper connection can result in a risk of an electric shock. This battery charger is for use on a nominal 120 volt circuit (common household current), and has a grounding plug. A temporary adapter may be used to connect this plug to a two- pole receptacle if a properly grounded outlet is not available. The temporary adapter should be used only until a qualified electrician can install a properly grounded outlet.

GENERAL GUIDELINES

GENERAL GUIDELINES contains important information for the safe operation and use of this Medical Device.

⚠ WARNING

1. Check all parts for shipping damage before using. In case of damage, **DO NOT** use the equipment.
2. The TUFFCARE patient lifter is **NOT** a transport device. It is intended to transfer a patient from one seated surface to another (such as from a bed to a wheelchair).
3. **DO NOT** attempt to transfer until the user is assessed by a qualified professional. Thoroughly read and fully understand the instructions in this Owner's Operating Manual.
4. TUFFCARE transfer slings are specifically designed to be used in conjunction with TUFFCARE patient lifters. Slings and accessories designed by other manufacturers are not to be utilized as a component of Tuffcare's patient lifter system.
5. The Rhino floor lifter is intended to be used for patient within weight limit indicated for the lifter. **DO NOT** attempt to lift more than the weight limit indicated.

⚠ WEIGHT LIMIT

DO NOT exceed maximum weight limit of the patient lifter. The weight limit for the patient lifter is 600 lbs.

⚠ ASSEMBLING THE LIFTER

DO NOT over-tighten mounting hardware. It will cause damage to the mounting brackets.

⚠ USING THE SLING

Before attaching the sling onto the hookup point on the swivel bar, lift the hanging straps up to predetermine which color coded hanging points to use in order to avoid the sides of the sling riding up to the underarm causing patient discomfort.

Be sure that sling is properly attached on sling holders before the patient is removed from a bed, chair, or any objects.

If the patient is in a wheelchair, secure the wheel locks in place to prevent the chair from moving forwards or backwards.

⚠ OPERATING THE LIFTER

Prior to first use, make sure that battery is being fully charged. Always use the handles to move the lifter.

⚠ LIFTING THE PATIENT

Adjustments for safety and comfort should be made before moving the patient. Patient's arms should be outside of the sling straps.

Before lifting a patient from a wheelchair, bed or any objects, slightly raise the patient off the object and check that sling attachments are secured.

During transfer, with the patient suspended in a sling attached to the lifter, **DO NOT** roll the base over uneven surfaces that would create an imbalance of the patient lifter and could cause the patient lifter to tip over. Use handle on the mast at all times to move the patient lifter.

ASSEMBLY

The lifter comes with pre-assembled main frame for easy assembly.

⚠ WARNING

Use only Tuffcare parts to complete this floor type patient lifter. For your safety, it is required to have a partner assist you with the lift assembly. Assembling the lift alone may lead to serious injury.

ASSEMBLING THE MAST ASSEMBLY TO THE BASE

1. Set base on the floor. Lock both rear casters before lifting up the mast.

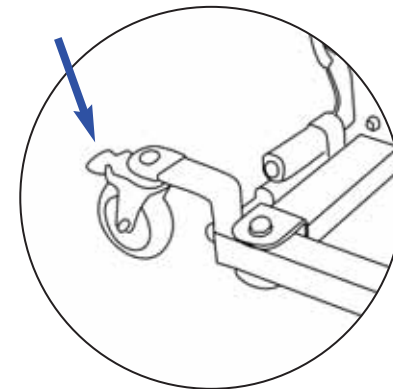

2. Lift up the mast to the mounting bracket on the base.

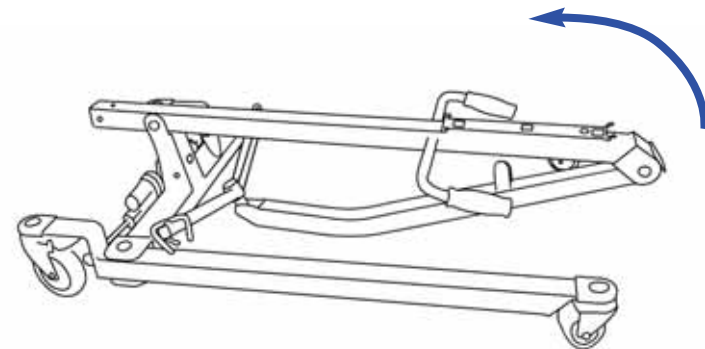

TUFFCARE suggests locking the rear casters **ONLY** when positioning or removing the sling (stand up or transfer) from around the patient.

TUFFCARE DOES NOT suggest locking the rear casters of the patient lifter when lifting a patient. When lift arm rises the center of gravity will shift and caster wheels will slightly move to balance the weight of the patient. Locking the rear casters could cause the lifter to tip over and endanger the patient and assistants.

⚠ TRANSFERRING THE PATIENT

Before transferring, check that the lifter's weight capacity can withstand the patient's weight.

Wheelchair wheel locks **MUST** be in a locked position before lowering the patient into the wheelchair for transport.

⚠ PERFORMING MAINTENANCE

Regular maintenance of patient lifter and accessories is required to assure proper operation.

Casters and axle bolts are also required to be checked for tightness.

DO NOT over-tighten mounting hardware. It will cause damage to the mounting brackets.

NOTE: See detail at Section 6 for maintenance.

⚠ PINCH POINTS

Pinch points exist at base of lifter. Use caution, otherwise injury could occur.

3. Use the included wrench to secure the bolts and nuts.

Note: The two longer bolts are used on the sides (upper & lower holes), short one is used on the middle.

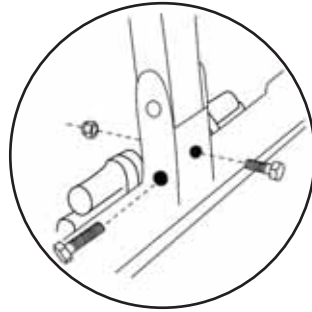

4. Check and tighten all hardware BEFORE use.

ATTACH THE UP-DOWN ACTUATOR TO THE MAST ASSEMBLY

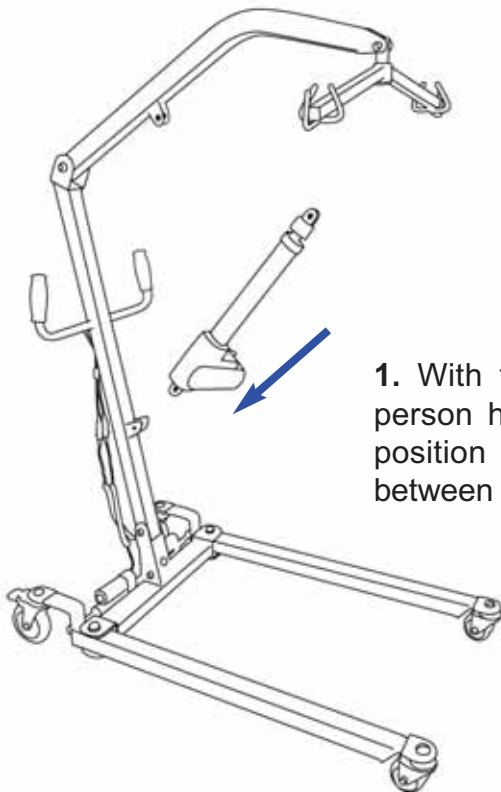

1. With the assistance of one person holding on the lift arm, position the up-down actuator between the mast bracket.

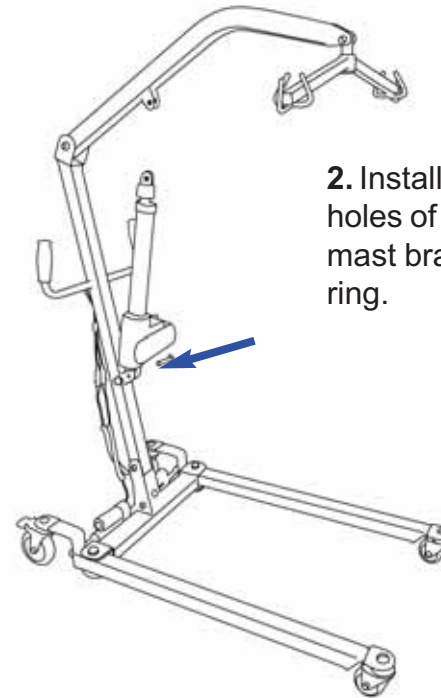

2. Install the clevis pin through the holes of the up-down actuator and mast bracket then secure with key ring.

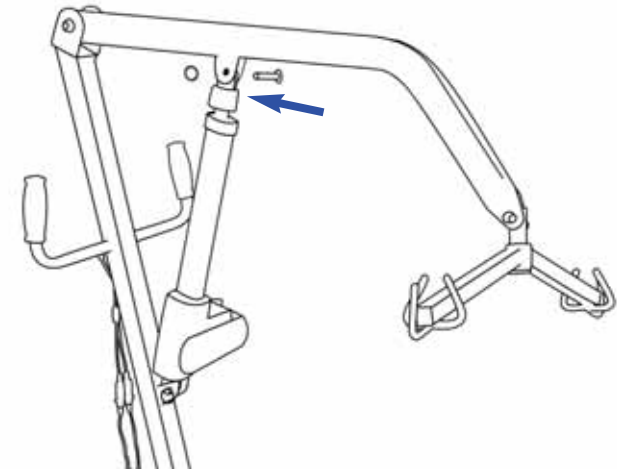

3. Move the lift arm to align the holes in the up-down actuator with the holes in the arm bracket.

4. Install the clevis pin through the hole of the up-down actuator and arm bracket then secure with key ring.

ATTACHING CONTROL UNIT

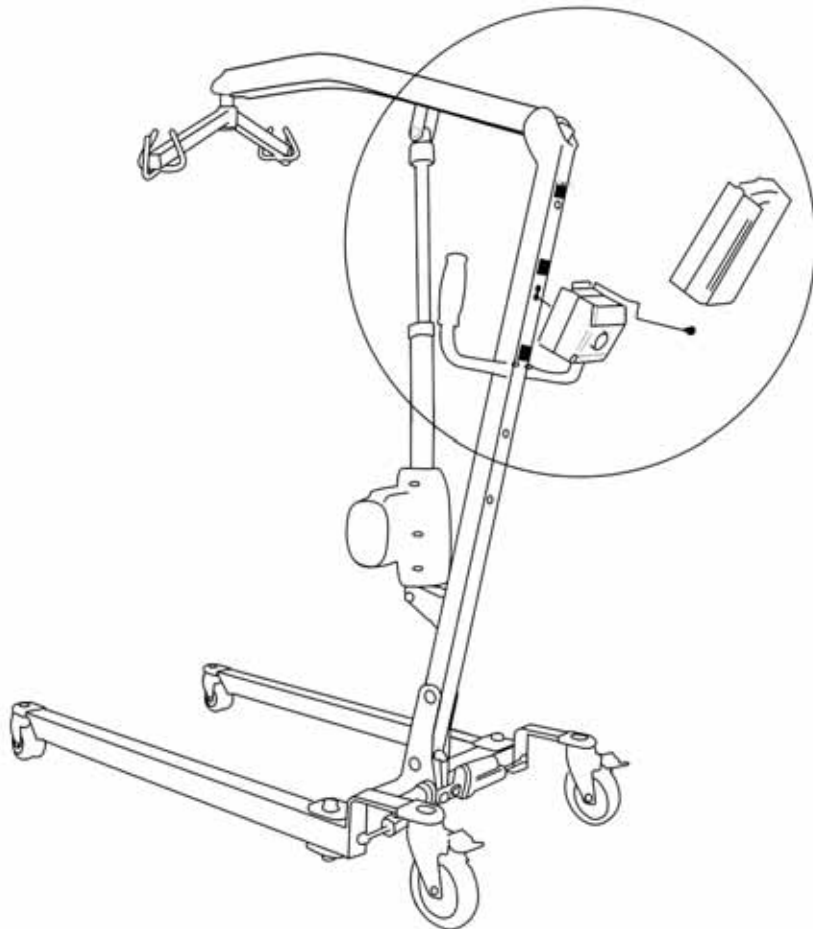

⚠ WARNING

Make sure there is an audible click when plugging battery pack onto the control unit. Otherwise, injury or damage may occur.

ATTACHING THE CONTROL UNIT ON THE MOUNTING BRACKET

1. Temporarily remove the controller setting screw from the mounting plate.

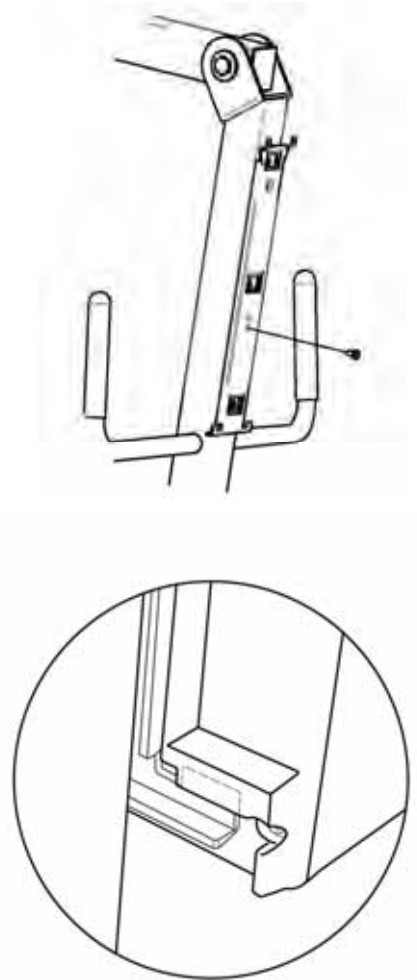
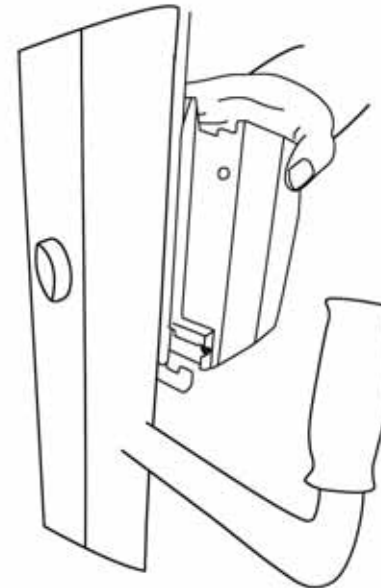

2. Align the controller to the mounting plate at about a 5 degree angle.

3. Make sure the 2 grooves at the lower back of the controller slide are positioned over the 2 extrusions at the bottom of the mounting plate.**

** **Caution:** Failure to do so will result in an inoperable state

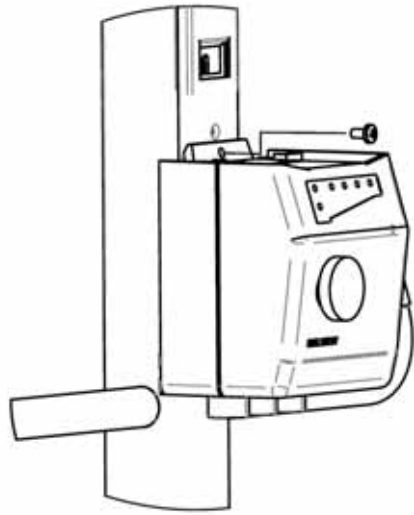

4. Place the controller mounting screw back into the same place and tighten.

ATTACHING THE BATTERY PACK ON CONTROL UNIT

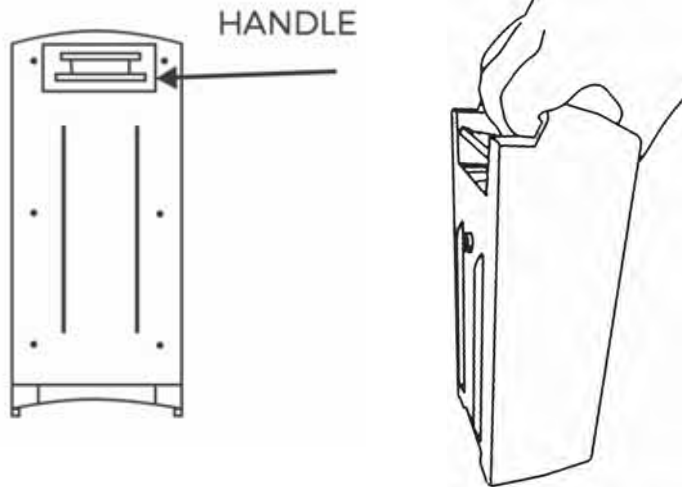

1. Hold the battery pack by its top handle on the backside of the battery. There is a spring loaded lever latch under the handle.

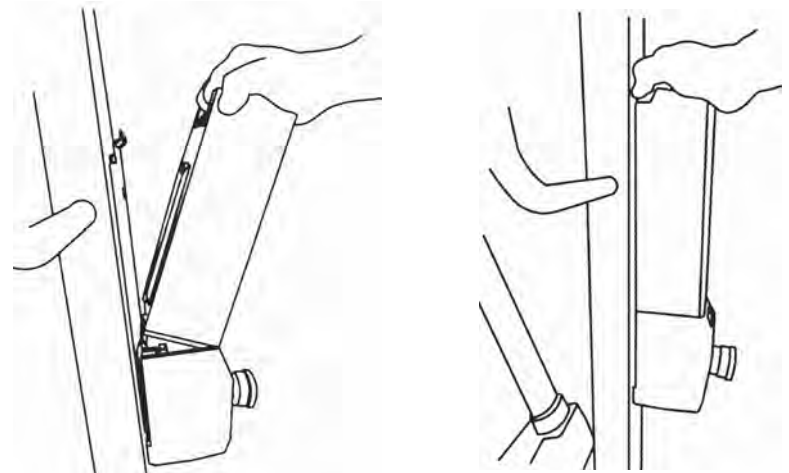

2. Set the battery pack on top of the controller at about a 5 degree angle.

3. While holding onto the lever latch inside the handle, move the battery pack parallel to the controller.

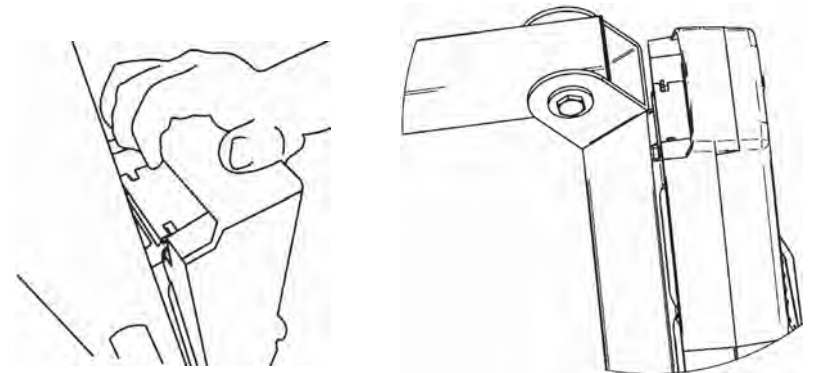

4. Make sure the latch plate is lifted up and set over the 2 extrusions at the top of the mounting plate.

5. Release the hold on the spring loaded lever latch. You will hear an audible click. The 2 holes on both sides of the latch plate should set on the 2 extrusion points on top of the mounting plate; securing the battery pack to the holder.

ATTACHING (OPTIONAL) SCALE

(Patient Lift Scale is to be Purchased Separately)

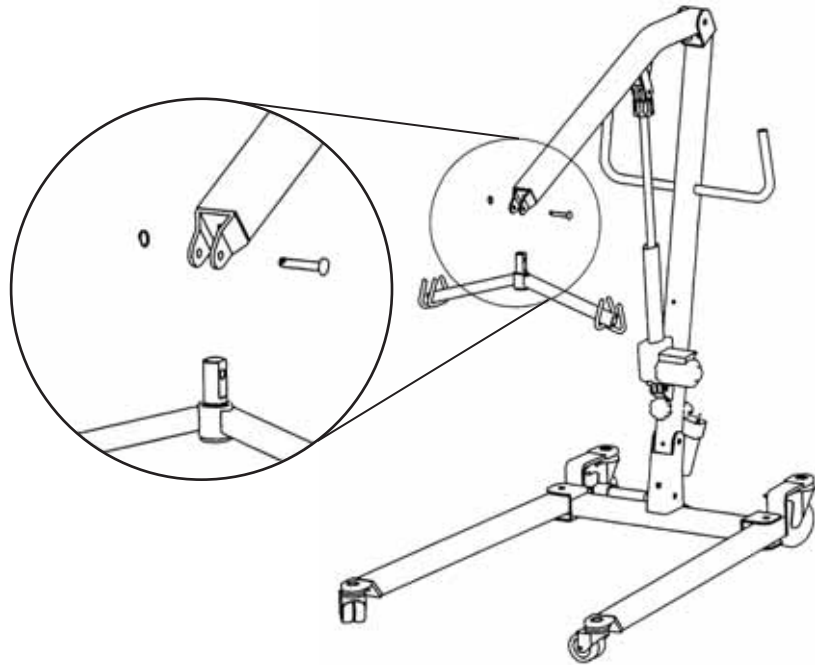

1. Remove the hanger bar from the lifter boom (pictured above).



Side Facing Display Scale

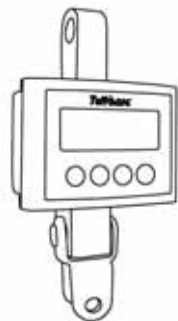

Front Facing Display Scale

A. Mounting Bracket



x 1

B. Clear Plastic Washer



x 2

C. Clevis Pin



x 2

D. Split Ring



x 2

E. Black Nylon Spacer



x 4

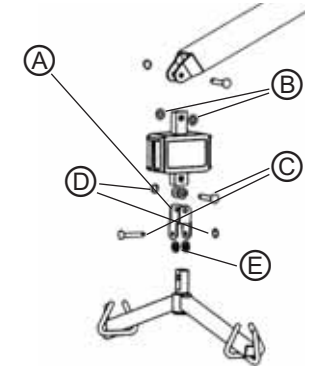

2. Insert the top plate of the digital scale into the lifter boom. Then secure the scale with the lifter's bolt and the clear washers.

3. Install the mounting bracket to the bottom of the digital scale and secure it with a clevis pin, black washers, and a split ring.

4. Insert the hanger bar onto the bottom of the mounting bracket and secure it with a clevis pin, black washers, and a split ring.

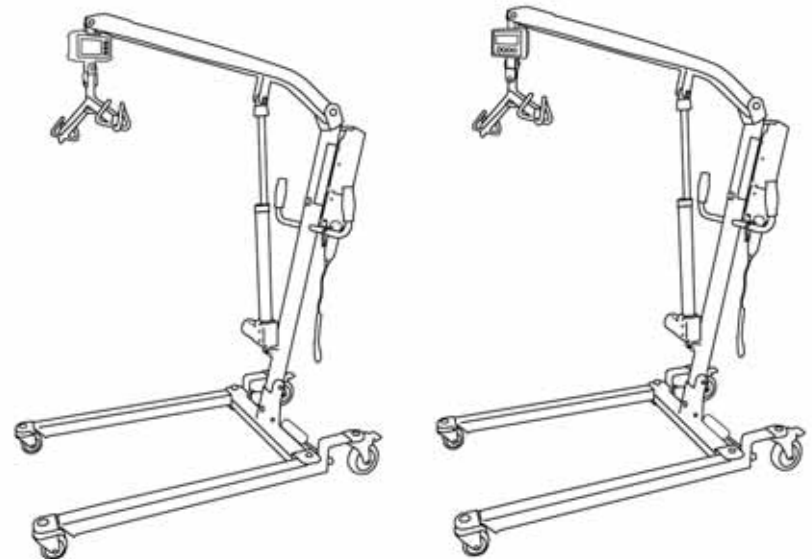

PREPARING THE PATIENT LIFT FOR USE

1. Plug the hand control, leg actuator (For P655 Full Electronic Lifters Only) and up-down actuator into the receptacles on the bottom of the control unit.
2. Check and tighten all hardware BEFORE operation.

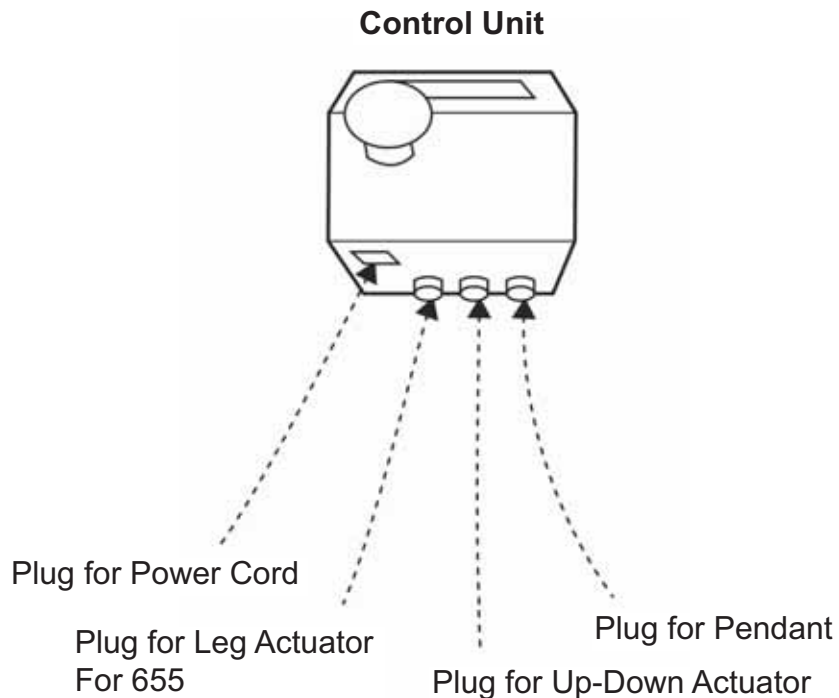

3. Plug the power cord into common household 110 or 220 Volt AC receptacle to charge the battery.

NOTE: When plugged into an AC outlet the safe protect feature turns on disabling the control pendent from functioning. The unit will not function while plugged in.

CHARGING THE BATTERY

NOTE: It is suggested to recharge the battery daily to prolong its life cycle.

1. Place the battery on the control unit to charge battery. Push the top of the battery against the mounting bracket until there is an audible click, See more details on pages (15-16) for Attaching the Battery Pack onto the Control Unit.
2. Make sure the red emergency button is fully pulled out and at the on position. (When emergency button is pressed down, the circuit is off and the unit will not function or charge.
3. Plug the power code into a 110 Volt outlet.

NOTE: When plugged into an AC outlet the safe protect feature turns on, disabling the control pendent from functioning. The unit will not function while plugged in.

NOTE: The charge LED will light up red while charging. When fully charged, the LED will stop illuminating.

NOTE: It will take approximately (4) hours to charge a battery that requires a full charge.



When the charging power cord is plugged into an electrical outlet, the red LED light on the left of the battery will come on. When the built-in charging system senses a drop in battery voltage, then the charging system automatically increases its output to re-charge the battery.

OPERATION

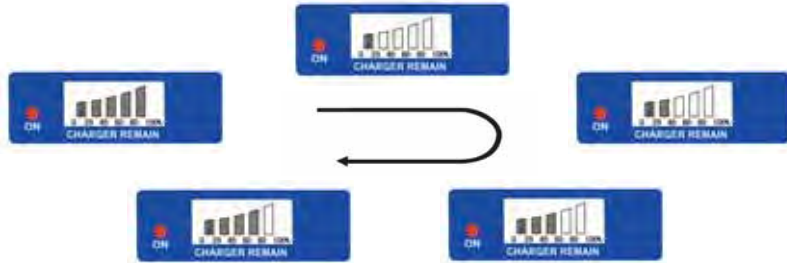

The bars on the battery meter will begin to flash based on the remaining percentage of the charge, the flashing bar slowly increases when the battery is taking charge. This indicates that the battery is charging on a fast mode “Bulk Charge”. Fast charging usually last for 30 min.

NOTE: If the charging cord is plugged in and the battery meter does not indicate this it suggests the circuit is off, the battery is fully charged, or a faulty battery(Have the battery pack replaced).

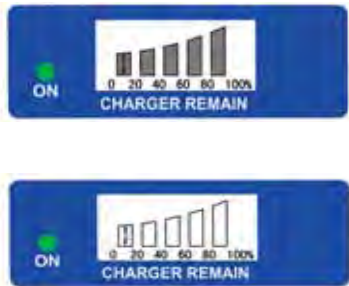

When the battery reserve reaches a desirable level the battery meter stops flashing and the LED turns from red to green. Now the battery meter will indicate a full gauge when all the bars light up. At this time the charger utilizes a slow charging “Absorption Charge”, leave charging for 4 to 6 hours.

When the battery becomes fully charged, the battery meter indicator bars turn off. Unplug the charging cord and the lifter will be ready for use.

⚠ WARNING

DO NOT attempt to transfer until the user is assessed by a qualified professional. Please thoroughly read and fully understand the instructions in this Owner’s Manual.

RAISING/LOWERING THE PATIENT LIFT



CONTROLS THE HI-LOW SECTION



PRESS To Raise the Patient Lift



PRESS To Lower the Patient Lift

CLOSING/OPENING THE LEGS



To Open and Close the Legs on P655
Press the open and close button on the hand control.

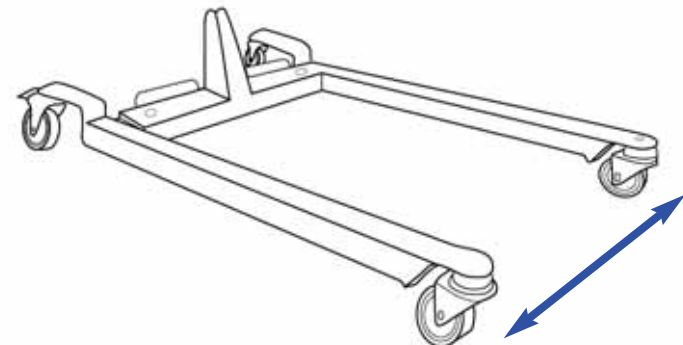

USING THE BACKUP HI-LOW BUTTON

The backup buttons for raising and lowering the patient lift arm are located on the right side of the battery LED gauge. Use a round pointed object to press for function.

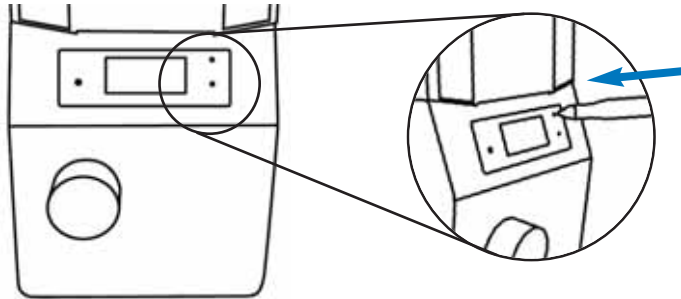

NOTE: Use these buttons only during hand pendant failure, replace the hand pendant as soon as possible. Use of the backup buttons as the main means of raising and lowering the lift arm will restrict the caregiver from moving around to assist the patient.

USING THE CIRCUIT OFF/EMERGENCY STOP

RED emergency button on Control Unit

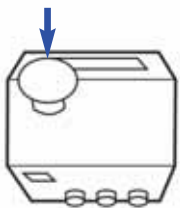

OFF/ Push the RED emergency button in to stop the lift arms from raising or lowering.

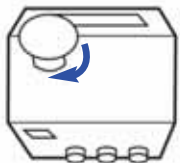

ON/ To reset, rotate the emergency button 1/4 turn clockwise, the button will pop-up; and an audible click can be heard when the circuit is engaged.

Red button out = Powered On Red button pushed in = Power Off

NOTE: When emergency button is pressed down, the circuit is off and the unit will not function or charge.

ACTIVATING A MECHANICAL EMERGENCY RELEASE

Emergency Release

To activate the emergency release, pull down the **Red Knob** located on the top-end of Up Down actuator drive shift.

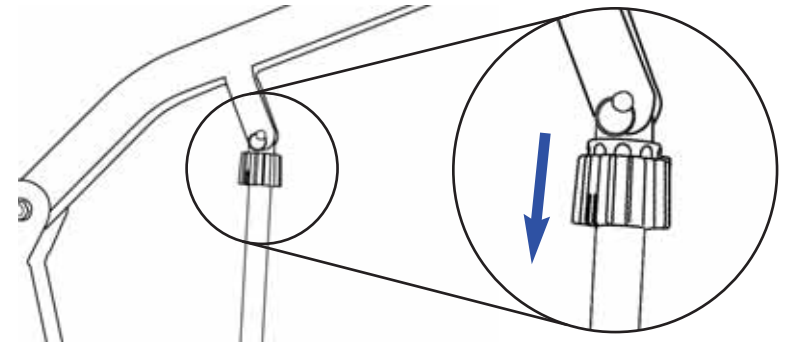

1. Rotate the Red Knob clockwise to slowly lower down the lift arm.
2. Turn the Red Knob counter-clockwise to slowly lift up the lift arm.

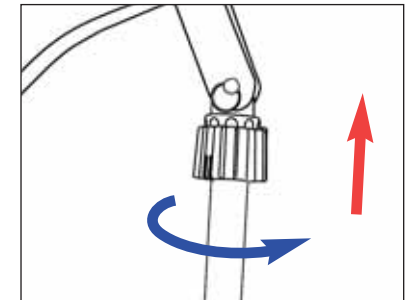
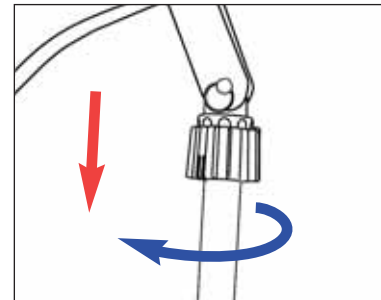

3. Push the emergency red release knob back up reengage the gears for normal operation.

LOCKING/UNLOCKING THE REAR CASTERS



LIFTING THE PATIENT

⚠ WARNING

1. **DO NOT** exceed the maximum weight limit of 650 lbs
2. **DO NOT** attempt to transfer until the user is assessed by a qualified professional. Thoroughly read and fully understand the instructions in this Owner's Manual.
3. **ALWAYS** keep hands and fingers clear of moving parts to avoid injury. Individuals that use the universal patient sling **MUST** be able to support their own weight, otherwise injury may occur.
4. **DO NOT** move the patient if the patient lift sling is not properly connected to the attachment hooks on the lifting bar. Check that the patient sling is properly connected to the attachment holders **BEFORE** lifting the patient.
5. During transfer, with the patient suspended in the patient sling, **DO NOT** roll the base of the patient lifter over any uneven surfaces that would cause the patient lifter to become unstable.
6. **ALWAYS** use the handle on the mast assembly to move the patient lifter to ensure the safety of the user.

POSITIONING THE PATIENT LIFTER

⚠ WARNING

The legs of the patient lifter **MUST** be in the maximum open position for stability and safety.

1. Open the leg section of the floor lift to obtain stability.
FOR P655:
Press the "FOOT" – "OPEN" symbol button on the hand control to open the legs to the maximum open position.

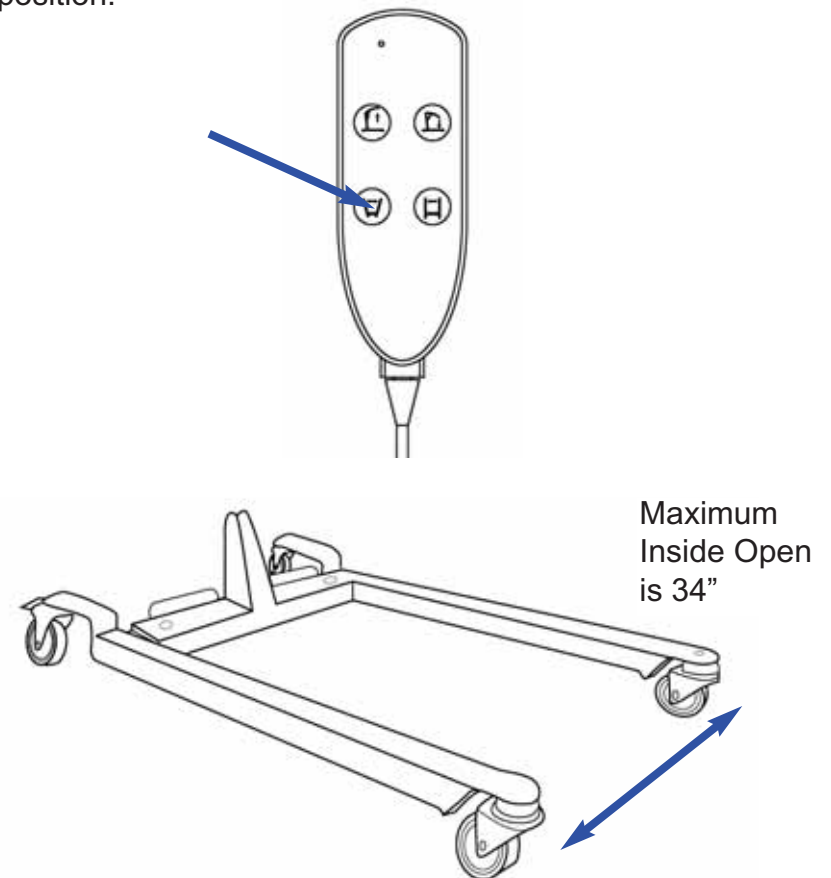

2. Position the patient lifter using the handle on the mast.

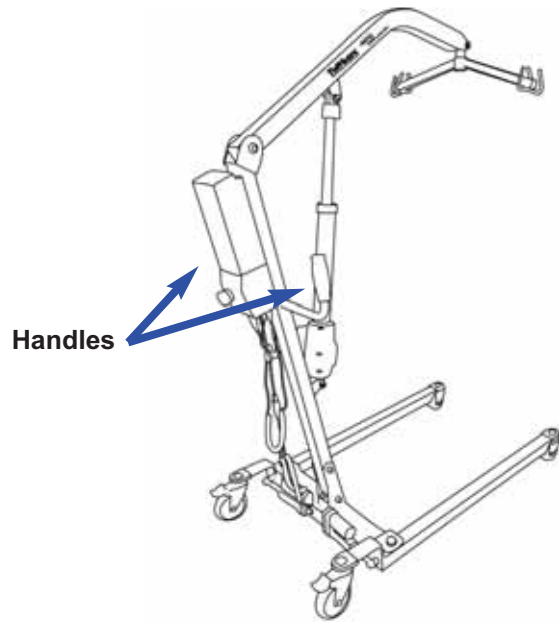

3. Press the "LIFT" – "DOWN" button on the hand control to lower the lift arms for easy attachment to the sling.

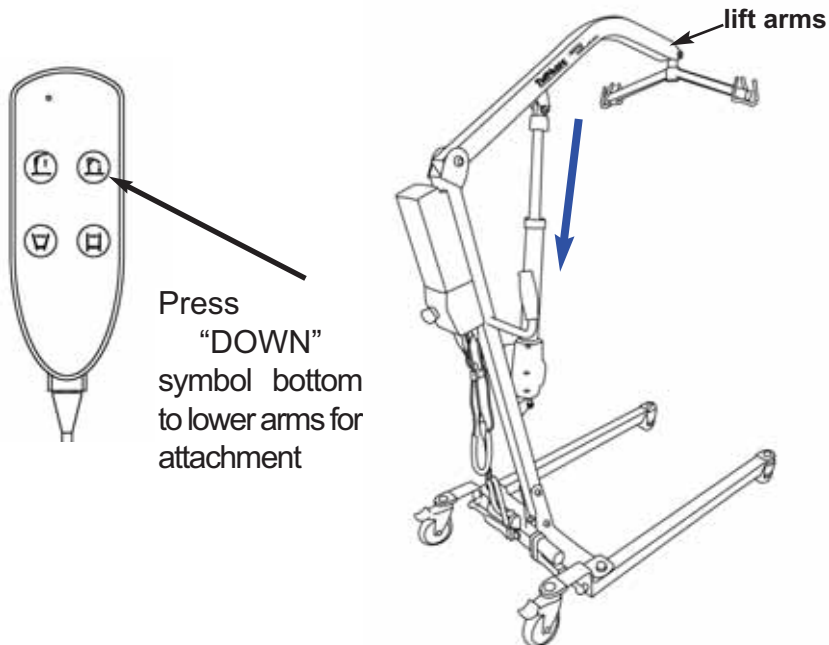

TRANSFERRING THE PATIENT

⚠ WARNING

DO NOT attempt to transfer until the user is assessed by a qualified professional. Thoroughly read and fully understand the instructions in this Owner's Manual.

DO NOT move the patient if the straps on the sling are not properly connected to the attachment hooks of the patient lifter. Check that the sling is properly connected to the attachment hooks prior to lifting a patient.

DO NOT use patient slings and patient lifter of different manufacturers. TUFFCARE slings are made specifically for use with TUFFCARE floor type patient lifter. Otherwise, injury or damage may occur. The legs of the patient lifter **MUST** be in the maximum open position for optimum stability and safety.

Be sure to check the sling attachments each time the sling is removed and replaced to ensure that it is properly attached before the patient is removed from a surface.

TRANSFERRING PATIENT FROM BED

1. Carefully and gently roll the patient on their side. The sling seat should be folded lengthwise and placed under the patient so that the lower edge of the seat is slightly below the back.

2. Now roll the patient back onto their other side and pull the sling seat so that it unfolds under the patient. Then pull the leg loops forward and under the patient's thighs. The loops should come through the patient's legs. Then cross the loops.

3. Roll the base of the patient lifter under the bed as far as

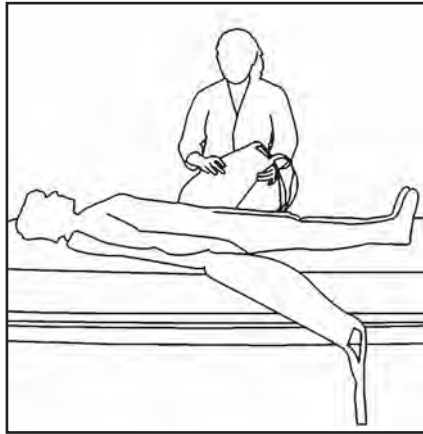
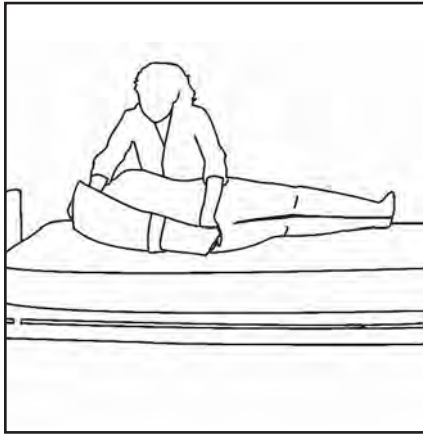

possible so that the cradle is directly over the patient. Lower the top bar and attach the loops on the sling to the hooks of the cradle.

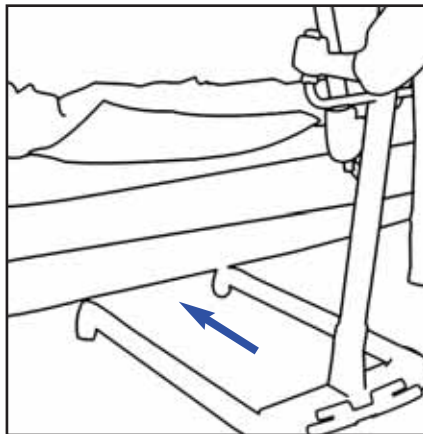
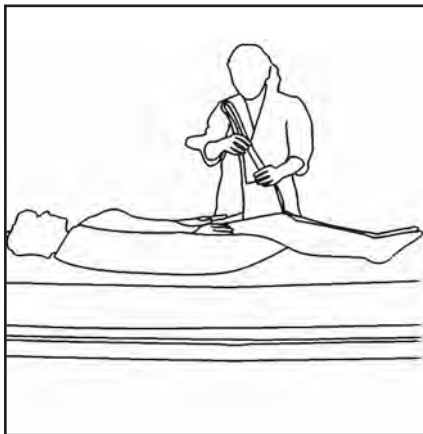

4. Elevate the patient into a upright position by raising the head of the bed or by using pillows.

5. Make sure the parking brake is not set. It will allow the lift to center itself beneath the patient.

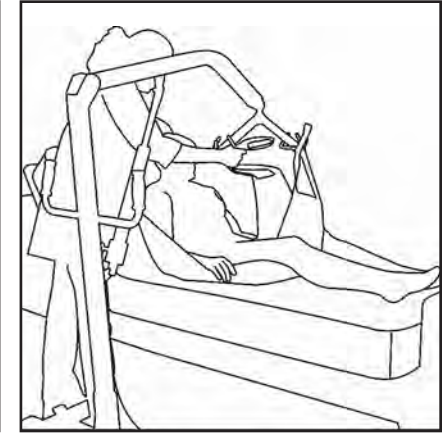
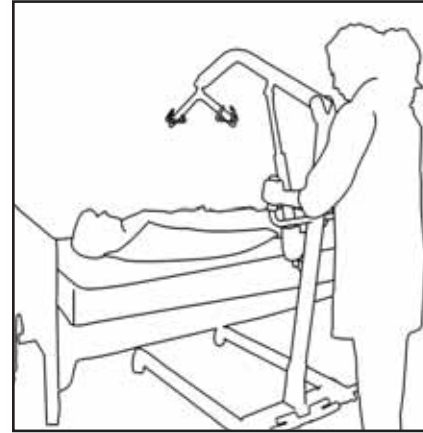

6. Raise the patient, make sure the patient is in a safe sitting position as the lifter rises.

7. As the patient is being raised, the cradle will level the patient into a seated position. Raise the patient until their buttocks are just above the mattress. Rotate the patient to face the lifter so that the legs dangle off the side of the bed.

8. Transfer the patient to wheelchair or other transport device by holding onto the push handles.

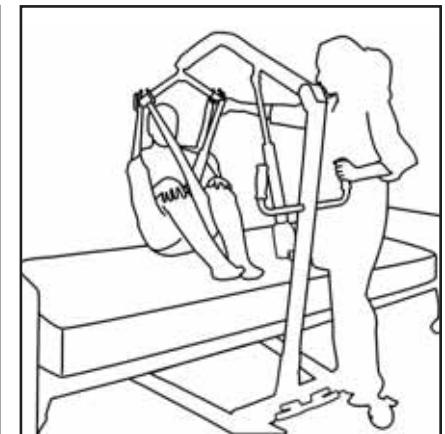
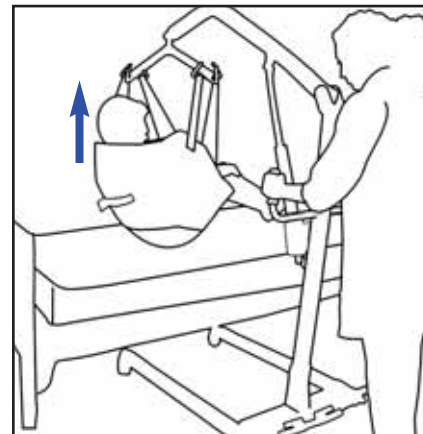

RETURNING PATIENT TO BED

1. Raise the lifter until the patient's buttocks are lifted above the mattress. If the patient can not be lifted above the bed try to lower the bed height. Do not push or pull patient onto the bed as this may tip over the lifter or injure the patient.
2. Move the patient lifter over the bed until the patient is approximately in the center. Lift the patient's feet and legs onto the bed. Gently rotate the patient to face end of the bed and slowly lower the patient onto the bed.

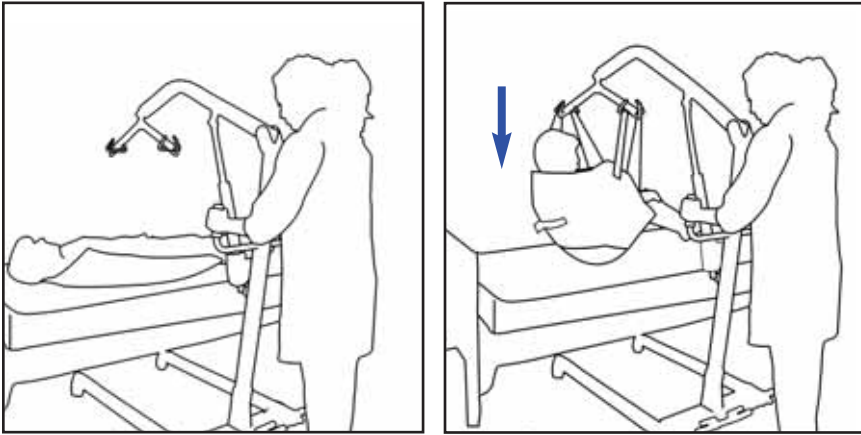

TRANSFER PATIENT IN LIFTER

1. When moving patients in the lifter try to keep the patient as low as possible. Keep the center of gravity low to the ground to avoid tipping over. Have the patient's feet rest on the base of the lifter. The patient must face the attendant at all times.
2. Push the lifter by grabbing on the the push handles. Do not attempt to go over deep carpet, small objects, or unpaved surfaces. Do not try to go up or down a slope over 5 degrees or one that's over the attendant's ability to handle.



⚠ WARNING

When elevated a few inches off the seating surface of the wheelchair and before moving the patient, check again to make sure that all hardware and straps/chains are properly connected. If any attachments are **NOT** properly in place, lower the patient completely to correct this problem.

Adjustments for safety and comfort should be made before moving the patient. Patient's arms should be inside of the chains or straps.

TUFFCARE slings and Hardware are designed specially for use with TUFFCARE Patient Lifter. For the safety of the patient, **DO NOT** intermix slings and patient lifter of different manufacturers.

NOTE: Tuffcare recommends that two assistants be used when transferring a patient to a wheelchair. Ensure the legs of the lifter (with patient) are in the maximum open position.

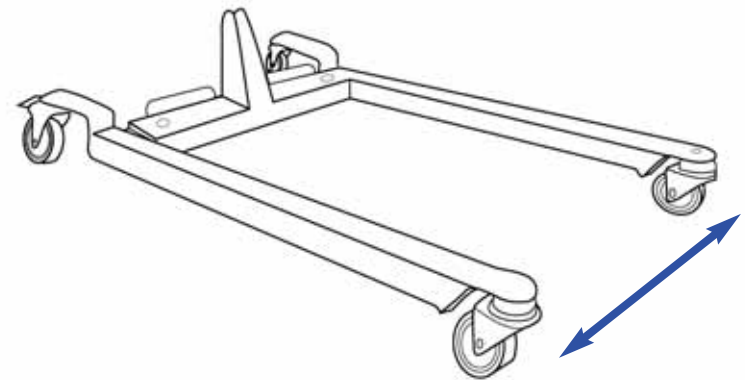

TRANSFERRING PATIENT FROM WHEELCHAIR

1. Secure the wheelchair from rolling back by engaging both wheel locks on the wheelchair.
2. Lean patient forward and set the folded sling behind the patient's back. Set the sling as far down as possible until it touches the back of the wheelchair seat.
3. Open the sling, pull the button loop section of the sling under patient's thighs then cross the loops



4. Move the lifter over the wheelchair and attach the loops to the cradle hooks. Then slowly raise the patient above the seat.

TRANSFERRING PATIENT TO WHEELCHAIR

1. First lock both brakes on the wheelchair. Position the lifter over the middle of the wheelchair seat.
2. Lower the lifter slowly and while descending, guide the patient into the chair by pushing on the knees until that the patient has reached a comfortable sitting position.
3. Detach the sling seat and roll the patient lifter away. Then remove the sling seat under the patient.



RAISE THE PATIENT FROM THE FLOOR

1. Roll the patient on their side and place the sling under the patient.
2. Move the lifter over the patient. Next place 1 or 2 pillows beneath the patient's head and shoulders, preventing any possible strain or injury when lifting the patient.

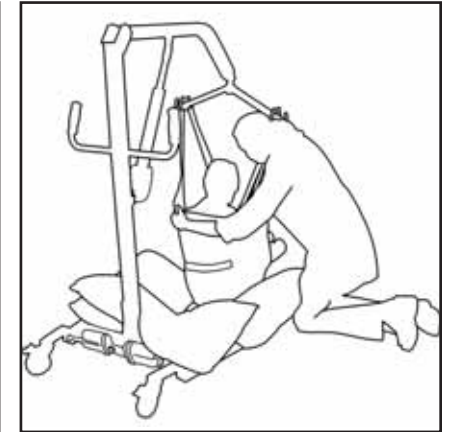
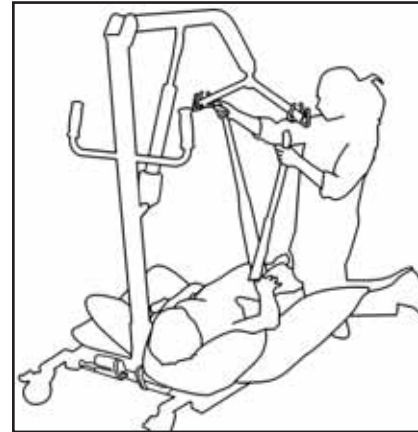

3. Lower the lifter so the loops on the sling can reach the hooks on the lifter bar, attach the loops.
4. Lift the patient off the floor. Turn the cradle so the patient is facing towards the upright bar. Rest the patient's legs on the base of the lifter.

LOWER THE PATIENT TO THE FLOOR

1. Before lowering the patient, the patient should be centered in the sling.
2. Place a few pillows on the base of the lifter, to prevent the patient from hitting the base. Then slowly lower the sling to the floor. While lowering make sure the pillows are beneath the patient's head.



TRANSFER FROM AUTOMOBILE

1. Park the automobile on a flat, smooth surface. Open the car door all the way.
2. Set a folded sling under the patient's back until the bottom of the sling touches the auto seat. Lift the patient's thighs and pass the end loops under the patient's legs. Cross the loops.

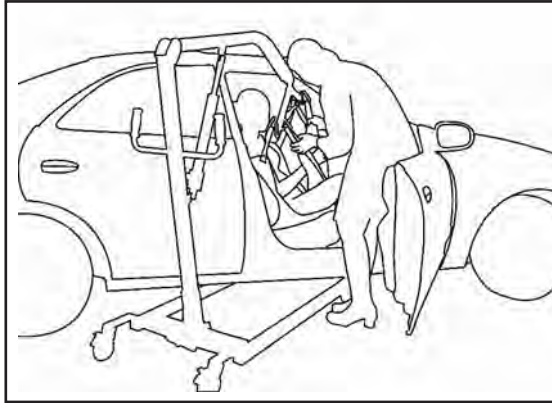

3. Lower the lifter's top bar so the cradle can clear the top of the door. Move lifter closer to auto so the loops on the sling can be attached to the hooks on the cradle.

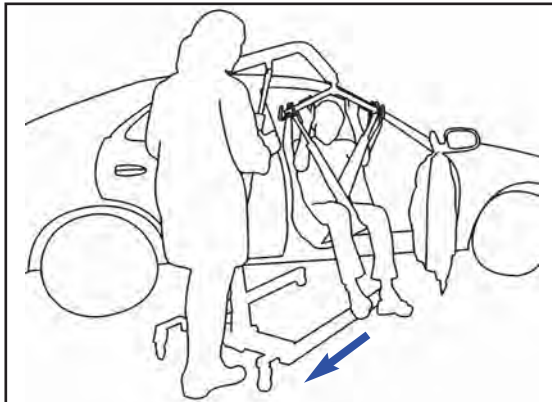

4. Raise the lifter slowly and move the lifter back an inch at a time. Repeat this process a few times until the patient's weight is rested on the sling.
5. Move lifter away from the car and rotate the sling so that patient is facing the attendant.

TRANSFER TO AUTOMOBILE

1. Push the lifter towards the car door. Approach the car with patient's back to the car seat.

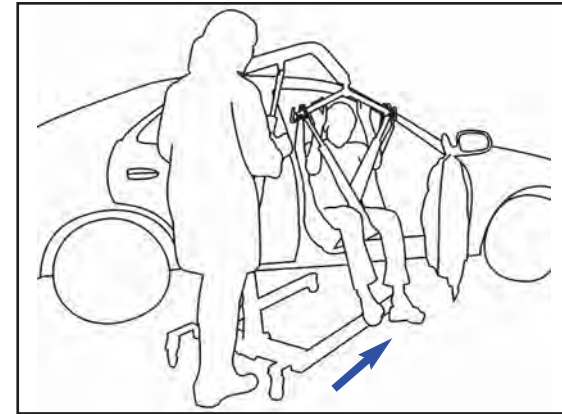

2. Lean patient forward and adjust the sling to correct height so their head will clear the car door. Continue to move the lifter forward until patient is inside the car.

3. Lift the patient's feet and legs inside the door and face the patient to the front of the car.

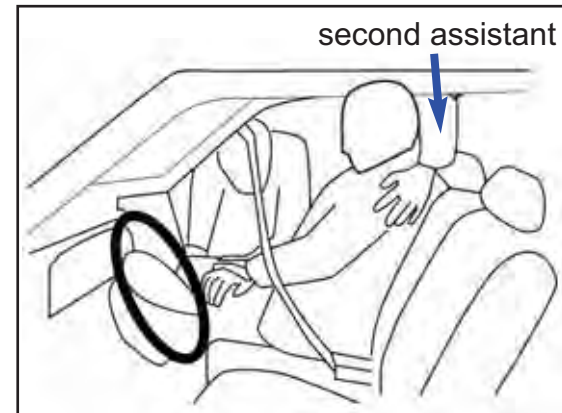

4. Slowly lower the lifter until the patient's weight is rested on the car seat. Remove the sling from patient's back or leave it behind patient for transferring out of the car when destination has been reached. The lifter can be disassembled and placed in a car trunk.

LIFT SLING TYPE REFERENCE

Tuffcare Rhino slings are made with a three layer soft but sturdy polyester fabric as well as a polyester mesh type of fabric which provides comfort and protects patients who may have sensitive skin. Along with preventing the patient from sliding in the sling, our Tuffcare Rhino slings are universal and will accommodate any 2, 4 or 6 point spreader bars from other suppliers.

FULL BODY SLINGS

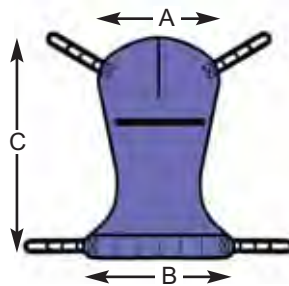

Model#	Size	A	B	C	Recommend Weight
P110	S	32"	39"	47"	55 - 110 lbs
P111	M	36"	43"	53"	99 - 210 lbs
P112	L	40"	47"	58"	198 - 350 lbs
P113	XL	42"	49"	63"	270 - 600 lbs

FULL MESH BODY SLINGS WITH COMMODOE OPENING

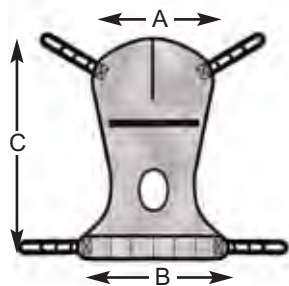

Model#	Size	A	B	C	Recommend Weight
P120	S	32"	39"	47"	55 - 110 lbs
P121	M	36"	43"	53"	99 - 210 lbs
P122	L	40"	47"	58"	198 - 350 lbs
P123	XL	42"	49"	63"	270 - 600 lbs

UNIVERSAL SLINGS

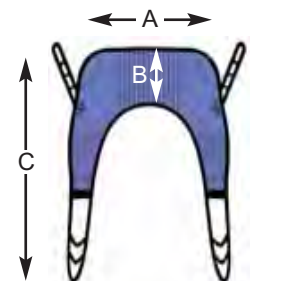

Model#	Size	A	B	C	Recommend Weight
P130	S	30"	18"	62"	55 - 110 lbs
P131	M	33"	21"	65"	99 - 210 lbs
P132	L	42"	22"	68"	198 - 350 lbs
P133	XL	46"	26"	72"	270 - 600 lbs

UNIVERSAL SLINGS WITH HEADREST



Model#	Size	A	B	C	Recommend Weight
P135	S	30"	18"	75"	55 - 110 lbs
P136	M	33"	21"	78"	99 - 210 lbs
P137	L	42"	22"	81"	198 - 350 lbs
P138	XL	46"	26"	85"	270 - 600 lbs

UNIVERSAL MESH SLINGS WITH HEADREST

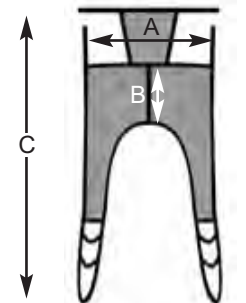

Model#	Size	A	B	C	Recommend Weight
P170	S	20"	18"	75"	55 - 110 lbs
P171	M	25"	21"	78"	99 - 210 lbs
P172	L	30"	22"	81"	198 - 350 lbs
P173	XL	36"	26"	87"	270 - 600 lbs

UNIVERSAL TOILETING SLINGS

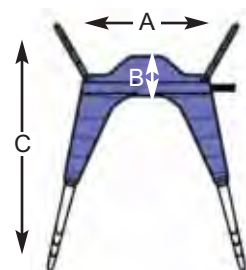

Model#	Size	A	B	C	Recommend Weight
P161	M	32"	9"	60"	99 - 210 lbs
P162	L	34"	10"	62"	198 - 300 lbs
P163	XL	37"	11"	65"	270 - 450 lbs

Belt: medium 22"- 40", large 35"- 53", x large 40"- 60"

HIP LIFT SLING

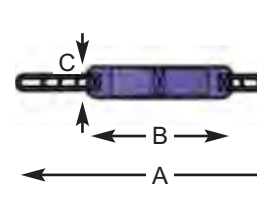

Model#	Size	A	B	C	Recommend Weight
P165	S	61"	31"	6"	55 - 110 lbs
P166	M	64"	34"	6"	99 - 210 lbs
P167	L	69"	39"	6"	198 - 350 lbs
P168	XL	74"	44"	6"	270 - 600 lbs

Belt: small 11"- 17", medium 14"- 20", large 19"- 25", x large 24"- 30"

MAINTENANCE

CLEANING THE LIFT

- The lift can be cleaned with non-abrasive cleaners. Make sure that the wheels are free of hair, lint and other debris.

DETECTING WEAR AND DAMAGE

- Check monthly that all screws are tight and have not loosened.
- Check monthly for damaged or exposed wires on the electrical components.
- Inspect monthly for signs of cracking, fraying, or any deterioration.
- Contact your equipment provider for replacement of any defective parts immediately and ensure that the lift is not used until repair job is completed.

LUBRICATING THE LIFT

- A light grease lubricant may be applied to the ball bearing and swivel of the casters every three months.

BATTERY MAINTENANCE

- Charge the battery to its full capacity at LEAST once a month to ensure its longevity.
- Do not leave the battery fully depleted or under 50% of its maximum charge for too long. Once battery falls under 50% of its capacity, it is recommended to fully charge it.
- After the battery reaches full charge, unplug the lift from the power source to prevent overcharging.

PERFORMING REGULAR MAINTENANCE

- Regular maintenance of the lift and accessories is required to ensure proper operation. The casters and axle bolts are also required to be checked for proper tightness.

TROUBLE SHOOTING

If the following solutions do not solve your issue, please contact your local representative.

Issues	Troubleshooting Steps
Actuator motor turns but lift arm does not move Cause: Stalls during movement.	This occurs when the emergency red knob, located at the top of the actuator shaft, has been activated. When the knob is activated it can cause the actuator shaft to spin in same spot instead of moving in the desired direction. If this occurs, put the knob back to its resting position by pushing it up towards the lift arm. You may need to rotate the knob a bit before it fits back into place.
Wheels struggling or unable to move Cause: Debris obstructing bearing	By unfasten the wheels from the caster forks one by one and clean any built up hair and debris to restore their proper functionality.
Battery will not full charge Cause: Prolonged discharge or battery life expectancy	Replace battery pack soon. If the battery is a few years old or has been improperly maintained it may be time to replace your battery. For more the proper maintenance procedures, please refer to the Battery Maintenance section on page #39. Failure to follow the provided maintenance guidelines will lead to batteries having shorter lives than expected.

<p>Lift is not charging or operating</p> <p>Cause: Circuit disengaged</p>	<p>Ensure the lift is plugged into a power source and turn the red dial on the control unit clockwise until you hear a click to engage the circuit. Make sure the charging cable, the hand pendant, and the motor(s) are properly plugged into the bottom of the control unit.</p>
<p>Lift is not charging or operating</p> <p>Cause: Bad contact</p>	<p>Check the back of the control unit to ensure that its bracket is properly mounted on the metal bracket with both of the bottom protrusions of the metal bracket sliding into the control unit's ridges on both sides. Then, remove the battery from the control unit and check the metal contact points on the top of the control unit and on the bottom of the battery. If any of metal contact points look like they are pressed down lift them up using a pen to allow for proper contact.</p>
<p>Lift is not charging or operating</p> <p>Cause: Battery attachment</p>	<p>Reattach the battery properly by pressing it against the bracket and sliding it down; making sure the latch clicks into place properly at the top. View the lift from the side to make sure the battery is parallel to the lift and that there are no large gaps between the battery and the control unit.</p>
<p>Lift is not charging or operating</p> <p>Cause: Charging or Sleep mode</p>	<p>After following these steps and charging the battery, unplug the lift from the power source. Ensure that the red dial on the control unit is still popped out then press and hold on the hand pendant for a second to get the control unit out of sleep mode. Then attempt to operate the lift by pressing and holding a up or down button on the hand pendant.</p>

LIMITED WARRANTY

The warranty below has been drafted to comply with Federal Law applicable to products manufactured after July 4, 1975. This warranty is extended only to the original purchaser/consumer (or dealer non-consumer who does not buy for resale).

Tuffcare® warrants that its Rhino Series patient lifters will be free from defective workmanship and materials for a period of three (3) years following the date of original manufacture with the following exceptions: All welds are warranted for the life of the lift. Electronics on the lifters are warranted for one (1) year. The warranty period commences on the original manufacture date. If within such warranty period any such product proven to Tuffcare® satisfaction to be defective, such product will be repaired or replaced at Tuffcare® option.

Tuffcare® sole obligation and your exclusive remedy under this warranty shall be limited to such repair and/or replacement. This warranty does not include any labor charges incurred in replacement parts installation. Freight charges to the factory are at the expense of the consumer or seller. Return freight charges will be prepaid by Tuffcare®. For warranty service, please contact the authorized dealer from whom you purchased your Tuffcare® products. In the event that you do not receive satisfactory warranty service, please write directly to: Tuffcare®: 4977 La Palma Ave, Anaheim, California, 92807.

DO NOT RETURN PRODUCTS WITHOUT PRIOR AUTHORIZATION.

LIMITATIONS AND EXCLUSIONS: The foregoing warranty shall not apply to products subjected to negligence, abuse, misuse, improper operation, improper maintenance, improper storage or damages beyond Tuffcare® control. The evaluation will be solely determined by Tuffcare®. The warranty shall not apply to problems arising from normal wear, or failure to follow instructions, or if parts are not manufactured by Tuffcare®, or do not comply with original equipment specifications that are added to Tuffcare® product.

THE FOREGOING WARRANTY IS EXCLUSIVE AND IN LIEU OF ALL OTHER WARRANTIES, INCLUDING BUT NOT LIMITED TO THE IMPLIED WARRANTIES OF MERCHANTABILITY AND FITNESS FOR A PARTICULAR PURPOSE AND SHALL NOT EXTEND BEYOND THE DURATION OF THE EXPRESS WARRANTY PROVIDED HEREIN. TUFFCARE® SHALL NOT BE LIABLE FOR ANY CONSEQUENTIAL OR INCIDENTAL DAMAGES WHATSOEVER.

This warranty gives you specific rights and you may also have other legal rights which vary from state to state. Some states do not allow the exclusion or limitations of incidental or consequential damage, or limitation on how long an implied warranty